

Plugs

- Protects unused and exposed pull stud holes from filling with contaminants
- Material: Delrin or 6061 Aluminum

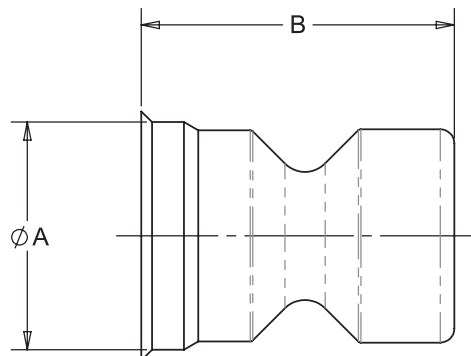

Part Number	A (mm)	B (mm)	Material	Weight lbs (kg)
QL-200820	16	22	Plastic	.01 (.005)
QL-200825	20	22	Plastic	.02 (.01)
QL-200830	16	22	Aluminum	.02 (.01)
QL-200835	20	22	Aluminum	.03 (.014)

Keys

- Used for aligning any of the Quick-Loc™ elements with bottom keyways to the t-slots of a machine table or rotary face.
- Material: Low Carbon Steel
- Heat Treat: Case Hardened, Rc 58-62

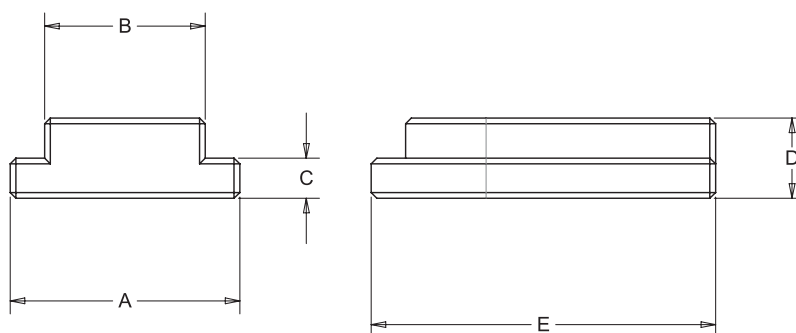

Part Number	A (mm)	B (mm)	C (mm)	D (mm)	E (mm)	Weight lbs (kg)
QL-200840	20	14	3.5	7	31	.02 (.01)
QL-200845	20	16	3.5	7	31	.03 (.014)
QL-200850	20	18	3.5	7	31	.03 (.014)
QL-200855	20	20	-	7	31	.04 (.02)